

SONODUR R

The fully automatable UCI hardness test instrument with the possibility of 100 % process monitoring in mass production





100 % process monitoring

The UCI (Ultrasonic Contact Impedance) hardness measurement technology of the SONODUR R provides a particularly suitable measurement technique for fast and reliable hardness testing on metallic components and materials in automated mass production. The hand and motor probes which can be combined with the SONODUR R, with different test forces from 1 N to 98 N, allow it to be used for almost all applications in quality assurance and production. The SONODUR R thus also permits special solutions and test methods for automated hardness measurement in the production line.

Thanks to USB and a fully isolated digital I/O interface, the UCI hardness measurement system is fully suitable for use in production lines. Target value specifications can be used to directly control settings such as good/bad sorting gates. The main field of application is the measurement of series production parts after heat treatment and/or surface processing.

The benefits:

- **Safety and cost savings:** Fully automated UCI hardness testing for 100% process monitoring.
- **Fast measurement:** Approx. 1 measurement per second: Minimum time required with maximum process reliability.
- **Operator-independent measurements:** Reproducible measurement for highest quality demands.
- **Maximum flexibility for a wide range of applications:** Ideally suited for use in fully automated production lines as well as for use as a tabletop unit.
- **Android-based software design:** Easy and intuitive handling of the software.
- **Large number of commercially available interfaces:** Maximum flexibility for connection to third-party systems.
- **The largest range of UCI probes on the market:** Enabling the best possible adaptation to individual application requirements.
- **Test method UCI method:** Our expertise for your safety. Complies with DIN 50159-1,2-2021, ASTM A1038-2019.

Professional software support



Operating system

The operating system of the SONODUR R is based on the future-proof Android platform with almost unlimited expansion options. The device is thus ideally equipped for 24/7 use as an in-line device for example in hardening shops and industrial plants. The user software of the SONODUR R is exemplary in terms of clarity and uncomplicated handling.

Highlights

- Fully isolated digital I/O interface for direct control of actuators; potential-free signal contacts for full remote control via PLC
- Measured value ticker with statistics function
- Fast amortization due to the long-life SONO probes
- Complete UCI SONO probe portfolio can be used
- RS232 interface for transmission of measurements
- Operation on 24 VDC voltage or external power supply
- Color-changing of measured value depending on the target value specifications

Technical data

Product features	SONODUR 3
Operating temperature	0 °C to +45 °C (32 °F to 113 °F)
Dimensions system (HxWxD)	approx. 133 x 236 x 314 mm
Weight of display instrument	approx. 3.4 kg
Operating system	Android 7.1
Power supply	12 - 24 VDC (max. 30 VDC), typ. 6 W, max. 23 W
Screen	Touch screen, TFT display with LED illumination
Size (inch / mm)	7.0" / 178 mm
Resolution	800 x 480 pixel
Colors / Brightness	262 K; 500 cd/m ²
Protection class	IP20
Instrument languages	DE, EN, IT, FR, ES, PL, CZ, CN - further on request

Test method

The SONODUR R hardness measuring system operates according to the UCI hardness testing method:

UCI test method

The rod of a UCI test probe is stimulated to oscillate in longitudinal direction with its natural frequency. A diamond is soldered into the lower end of the rod, which is pressed into the material in order to perform a measurement. With it a defined load is applied via a spring system. When the Vickers diamond penetrates towards the material, the vibration is damped and a frequency shift occurs, which can be measured. When the nominal test force has been reached within the final position, the hardness value is calculated from this frequency shift using the Vickers scale and will be displayed immediately. Due to the small indentation size and depth, the process is often considered to be non-destructive.

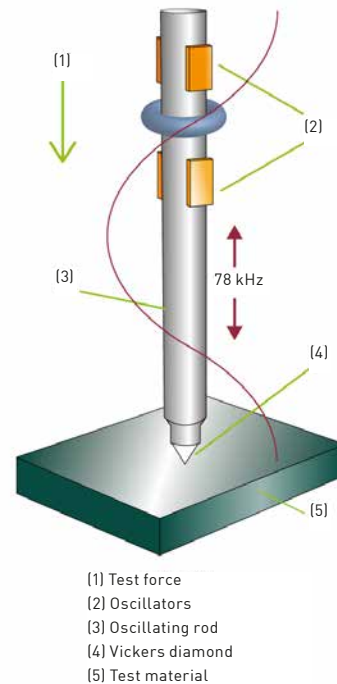

Fig. 1: Mobile hardness testing with UCI

Standards

Compliance with international standards forms an important part of professional quality assurance and ensures the high quality of the end product. Units and systems by FOERSTER perform testing in accordance with these international standards to ensure that your materials and components meet the tough requirements.

Below is a selection of standards covered by the SONODUR 3 test system. Please do not hesitate to contact us should you wish to perform testing in accordance with any standards that are not listed.

- UCI method, according to DIN 50159-1,2-2021, ASTM A1038-2019
- Conversion according to the latest ASTM E140-12b1 [2019] and EN ISO 18265:2019.

Hardness reference blocks for UCI

Highest demands on quality and homogeneity

Our hardness reference blocks with factory certificate (on request also with DAkks certification) enable continuous checking and calibration of your UCI probes for consistently stable measurement results.

The hardness reference blocks are available in different versions from 100 HV to 900 HV with certified hardness.



Metrology

Test method	UCI method according to DIN 50159, ASTM A1038
Test probe (indentation body)	Vickers diamond 136°
Test forces Newton scale (1 kgf = 9.81 N)	Motor probes: 1 N (0.1 kgf), 3N (0.3 kgf) and 8.6 N (0.9 kgf) Hand probes: 10 N (1 kgf), 49N (5 kgf), 98 N (10 kgf) (Other test forces on request)
Hardness scales and conversion ranges (according to the respective standard) here table A1 or T1, T2 (low alloy steel). For other materials, different different conversion ranges apply. Notice: Revaluations according to the latest ASTM E140 and EN ISO 18265. Conversion to tensile strength for 98 N (10 kgf)	Vickers HV 10 - 1999 (9999) Brinell HB 76 - 618 Rockwell HRB 41 - 105 Rockwell HRF 82.6 - 115.1 Rockwell HRC 20.3 - 68 Rockwell HRA 60.7 - 85.6 Rockwell HRD 40.3 - 76.9 (EN ISO 18265 only) Rockwell HR45N 19.9 - 75.4 Knoop HK 87 - 920 (ASTM only) Tensile strength MPa 255 - 2180 (EN ISO 18265 only)
Uncertainty of measurement*	< 4 % (HV5, HV 10). For other forces and measuring ranges see table.
Repeatability*	< 5 % (HV5, HV 10). For other forces and measuring ranges see table.
Interfaces	Probe connector: Lemo ERD.0S.304, USB level Digital interface: 37-pin D-Sub with filter, isolated, max. voltage 30 VDC USB 2.0: USB device, type B RS232: 9-pin D-Sub, V24 level

* Better than DIN 50159, depending on test load and measuring range (see table). The data are valid for 5 measurements on Vickers hardness reference blocks and test conditions according to DIN 50159.

Probe overview and applications



SONO H

Stable and reproducible measured values

The measuring probes are designed for daily use. The robust stainless steel housing is corrosion resistant and the basis for the special, long-life probe technology that is inside.

The intelligent measuring system of each probe covers the entire hardness range of the classic Vickers scale. The hand-held probes are suitable for measurements of metals, industrial ceramics and, with certain restrictions, also for highly heterogeneous materials such as cast iron (nodular cast iron e.g. GJS500).



SONO S

Guided measurements for demanding measuring positions or fully automatic operation

The SONO S series combines the SONO H measuring probes in a high-quality stand housing. The integrated guide and the multi-part set of probe attachments - with and without prism - enable the probe to be positioned cleanly even on curved surfaces and the measurement to be performed precisely and reproducibly. Transverse forces are virtually eliminated. Further applications can be found wherever a hold-down is required or an adaptation with self-centering makes sense on unevenly curved surfaces.

The SONO S is particularly suitable for automated applications as the probe guide is already integrated. This eliminates the need for complex guides for integration into the line.



SONO M

Repeatable, uniform application of force into the material to achieve highly accurate measurements

The rugged, mechanical construction of the motorized measuring probes is designed for everyday industrial use. The solid anodized aluminum housing protects the sophisticated mechanics. The intelligent measuring system of each probe covers the entire hardness range of the classic Vickers scale. Motorized probes operate with significantly lower test forces than hand-held probes, making them particularly suitable for sensitive surfaces on which only minimal test indentations are to be made.

The field of application includes thin, sensitive surface layers such as in the printing industry, for pistons and plating as well as sensitive components and materials. The probes are equally suitable for measuring surface hardness in the copper gravure printing industry or the automotive industry.



Integration

FOERSTER - Your partner for comprehensive automation solutions

FOERSTER offers comprehensive advice on integrating the measuring device into your production line. The integration of the automation solution is then handled by the customer or an automation partner.

Please feel free to contact us.

Unit connections



All unit connections and the on/off switch are located on the rear of the instrument.

Features

- **Toggle switch** for switching the device on or off
- **Interface Digital I/O** for digital input and output - signals, galvanically isolated
- **USB port** for data transfer to PC/network and for software updates
- **COM 1 interface** - RS232 as serial interface. For data output and remote control, galvanically isolated
- **COM 2 interface** - possible to be integrated on request
- **Connection of the power supply** with 24 VDC / 1 A min
- **Connection socket (LEMO)** for the probe cable, coded and locked (push-pull)
- **Network connection** as LAN interface - possible to be integrated on request

Headquarters

- Institut Dr. Foerster GmbH & Co. KG; Germany

Are you looking for a contact person in your market? Contact us at sales.mt.de@foerstergroup.com or by phone via +49 7121 140 0.

The FOERSTER Group is being represented by subsidiaries and representatives in over 60 countries – worldwide.

Institut Dr. Foerster GmbH & Co. KG

In Laisen 70

72766 Reutlingen

Germany

t +49 7121 140 0

info@foerstergroup.com

