

PRODUCT INFORMATION



# KOERZIMAT 1.097 MS

MS Measuring Systems

---



proof.

During the production process of steel, hard metals and powder metallurgical components magnetic values such as coercive field strength  $H_cJ$ , weight-specific saturation polarization  $\sigma_s$  and the volume-specific saturation polarization  $J_s$  correlate to a variety of important process parameters and material properties.

With the KOERZIMAT 1.097 MS FOERSTER offers a measuring system for the precise, automatic and economic measurement of the weight-specific saturation polarization  $\sigma_s$  and the volume-specific saturation polarization  $J_s$ . As the measurement is geometry-independent it enables especially for testing of specimen with complex shape.

### Testing method

- Withdrawal method in accordance with IEC-60404-14

### Measurement

- Weight-specific saturation polarization  $\sigma_s$  ( $T \cdot m^3/kg$ )
- Volume-specific saturation polarization  $J_s$  [Tesla]
- Magnetic portion MA [%]
- Dissolved tungsten in cobalt W [%]
- Magnetic dipole moment  $j$  [ $Vsm / T \cdot m^3$ ]
- Magnetic phase of high-alloy steels MP [%]

### Applications

- Hard metal testing acc. to ASTM B886
- Quality control of sintering process of hard metals
- Determination of carbon content [Eta-Phase] in hard metals
- Determination of the portion of dissolved tungsten in cobalt in hard metals
- Determination of the free iron, cobalt or nickel content in metal powder or hard metals
- Determination of the saturation polarization  $J_s$  in Tesla for soft magnetic components designed for magnetic circuits
- Indirect density control of powder-metallurgically produced soft-magnetic materials
- Research and development of new alloys and magnetic materials
- Determination of the theoretic magnetic phase of alloy steel according to Hoselitz
- Indirect determination of martensite/austenite or ferrite in stainless steel/dual phase steel

---

## Mode of operation

The KOERZIMAT 1.097 MS systems consist of a strong permanent magnet (Halbach array) with a big air gap for loading the test specimen.

A pneumatic or manual test specimen feeder provides the specimen into the homogenous area of the magnet. By withdrawing the specimen the magnetic dipole moment  $j$  is measured by means of the Helmholtz coils and a fluxmeter.

To determine the weight- or volume-specific saturation polarization, a precision scale is needed. The mass of the specimen is determined and directly be transferred to the KOERZIMAT controller. For the determination of the volume-specific saturation polarization  $J_s$  the volume/density of the specimen is additionally required.

## Specimen mass and sensitivity of the measuring system

Depending on the measurement range selected following maximum specimen mass can be measured:

- |                    |                 |                 |
|--------------------|-----------------|-----------------|
| - Pure cobalt (Co) | 16 g (standard) | 40 g (extended) |
| - Pure iron (Fe)   | 12 g (standard) | 30 g (extended) |

The smallest possible specimen mass is:

- |                    |                   |                   |
|--------------------|-------------------|-------------------|
| - Pure cobalt (Co) | 0,5 mg (MS 31x69) | 0,1 mg (MS 26x60) |
|--------------------|-------------------|-------------------|

## KOERZIMAT 1.097 MS 31x69



### Features

- High sensitivity for small test specimen  $\geq 1g$
- Measurement of large test piece weights up to 200g
- Compact, lightweight design by Halbach array
- Pneumatic test specimen feeder incl. slide
- Geometry-independent measurement
- Automatic slide compensation
- Loading and fitting of the test specimen by test inserts
- Calibration traceable to national standards [PTB]
- Accessory kit with inserts for test piece fitting

- ▶ Test specimen chamber approx. 41 x 58.5 x 23 mm

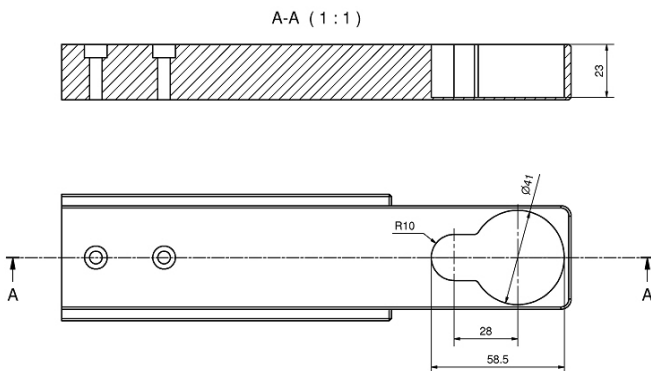

## KOERZIMAT 1.097 MS 26x60

### Features



- Highest sensitivity for very small specimen  $\geq 0,5g$
- Measurement of large test piece weights up to 50g
- Compact, lightweight design by Halbach array
- Manual operation of the test specimen slide
- Test specimen slide for round bars  $\varnothing 3-10mm / 10-15mm$
- Geometry-independent measurement
- Automatic slide compensation
- Loading and fitting of the test specimen by test inserts
- Calibration traceable to national standards [PTB]
- Accessory kit with inserts for test piece fitting

- Test specimen chamber about 30 x 40 x 18 mm

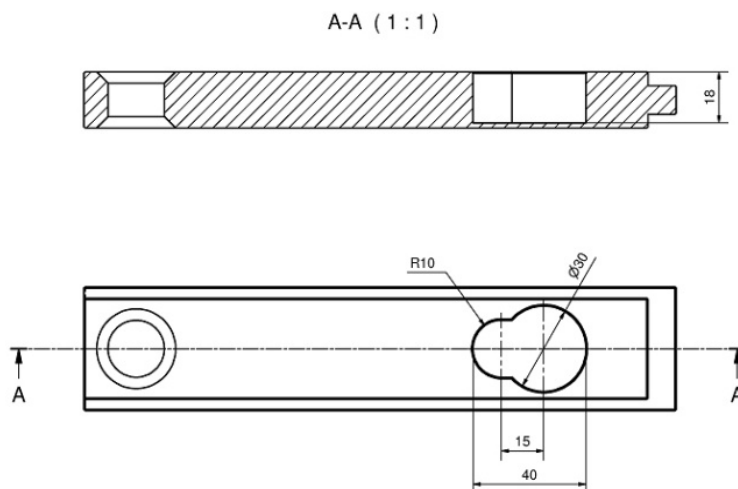

## KOERZIMAT Controller / Software MS

The compact KOERZIMAT Controller with MS Software forms a unit as a display and user interface for the MS measuring. The KOERZIMAT MS Software runs under Windows 8 Pro/10. Intuitive touch screen functionalities are available and assist the handling of the measuring control.

All measuring data are stored in a database (FOERSTER-owned format – from software version 6.0 upwards) and can be printed in a report or exported in a text file for further processing.



### Features

- User interface language: GERMAN, ENGLISH, JAPANESE
- WINDOWS 8 /10 country settings/languages online selectable
- Touchscreen operation
- Clearly structured display elements for measuring adjustments, value output in listed form
- Series measurement graphics, histogram, sorting groups and statistics
- Generating, print out and export of measured values/ statistics
- Password protected user levels for administration of functions and user access
- FOERSTER-owned database format – software version 6.0, storage of measuring data and parameters
- Synchronization of the database whilst measuring HCJ and MS
- Export of data via data interface in XML format (from software version 6.1 upwards)  
Remote-client-program is included in the scope of supply

## Technical Specification

### KOERZIMAT 1.097 MS 31x69

Display elements	8 LEDs for status display
Maximum specimen mass	approx. 200 g
Dimensions of the test specimen chamber (W x L x H)	41 x 58,5 x 23 mm
Magnetic flux density	1,15 T
Homogeneous area	Ø = 32 mm, h = 21 mm
Temperature coefficient	$12,5 \times 10^{-8} \text{ Tm}^3/\text{kgK} \approx 0,625 \text{ mg Co/K}$
Noise	$5 \times 10^{-8} \text{ Tm}^3/\text{kg} \approx 0,25 \text{ mg Co}$
Sensitivity	$1 \times 10^{-7} \text{ Tm}^3/\text{kg} \approx 0,5 \text{ mg Co}$ i.e. 1g specimen with 10 % cobalt content (100 mg) provides a measuring value 200 times higher than the sensitivity limit of the system
Measurement uncertainty when calibrating with Ni standard	< 0,5 % of measured value
Linearity (% of full range)	± 0,1 %
Temperature range	+5 °C to +45 °C
Measuring time	approx. 10 s (without weight determination)
Interface LAN	100 MBit
Interface I/O-Port	15-pin (Start button and 4 PLC input/outputs, 24 V)
Power supply	Plug-in power supply unit 100 to 240 VAC, 50/60 Hz
Power consumption	approx. 2 W
Compressed air connection	By quick-coupling with filter regulating unit 6 bar
Dimensions measuring system (W x H x L)	approx. 265 x 280 x 460 mm
Mass	approx. 29 kg
Protection class	IP53
Testing standard / testing method	IEC 60404-14 / ASTM B886

## Technical Specification

### KOERZIMAT 1.097 MS 26x60

Display elements	8 LEDs for status display
Maximum specimen mass	approx. 50 g
Dimensions specimen space (W x L x H)	30 x 40 x 18 mm
Homogeneous area	Ø = 26 mm, h = 16 mm
Magnetic flux density	1,15 T
Temperature coefficient	$2,5 \times 10^{-8} \text{ Tm}^3/\text{kgK} \approx 0,125 \text{ mg Co/K}$
Noise	$1 \times 10^{-8} \text{ Tm}^3/\text{kg} \approx 0,05 \text{ mg Co}$
Sensitivity	$2 \times 10^{-8} \text{ Tm}^3/\text{kg} \approx 0,1 \text{ mg Co}$ i.e. 1g specimen with 10 % cobalt content (100 mg) provides a measuring value 1000 times higher than the sensitivity limit of the system
Measurement uncertainty when calibrating with Ni standard	< 0,5 % of measured value
Linearity (% of full range)	$\pm 0,1 \%$
Temperature range	+5 °C bis +45 °C
Measuring time	3 s (without weight determination)
Interface LAN	100 MBit
Power supply	Plug-in power supply unit 100 to 240 VAC, 50/60 Hz
Power consumption	approx. 2 W
Dimensions measuring system (W x H x L)	approx. 172 x 217 x 230 mm
Mass	approx. 13.9 kg
Protection class	IP 53
Testing standard / Testing method	IEC 60404-14 / ASTM B886



---

## Standard Kits

### **KOERZIMAT 1.097 MS 26x60**

Consisting of:

- KOERZIMAT 1.097 MS 26x60 mm
- Accessory-Kit 26 x 60

### **KOERZIMAT 1.097 MS 31x69**

Consisting of:

- KOERZIMAT 1.097 MS 31x69 mm
- Accessory-Kit 31x69

### **KOERZIMAT Controller + KOERZIMAT MS Software**

Consisting of:

- 23,8" Touch screen
- Processor: Intel Core i5-7500, 3,4 GHz, 6 MB, Graphic card
- Memory : 8 GB (1x8 GB) 2400 MHz DDR4 Non-ECC
- Hard drive: 500 GB, 2,5 inch, serial ATA
- 2 x USB 2.0 and 5 x USB 3.0
- 1 x LAN, 1 x HDMI
- DVD-drive
- Optical mouse with USB cable
- USB keyboard
- Language preferences
- Language recognition, if activated
- WINDOWS 10 PRO 64 BIT operating system
- KOERZIMAT MS software MS with dongle

## Additional Software Option

### **KOERZIMAT MS Software –Magnetic phase**

[not included in standard KOERZIMAT MS-Software]

## Calibration Standards

### **Calibration standard MS Nickel**

with certificate

### **Calibration standard MS Iron**

with certificate

## **Analytical scale / density kit**

### **Analytical scale XS204DR**

With high wind guard – Brand: METTLER TOLEDO

Weighing range: 0...220g

Reading precision: 0,1 mg

### **Density kit for XS204DR**

Brand: METTLER TOLEDO

## **Specimen slide for KOERZIMAT 1.097 MS 26 x 60**

**Specimen slide for round bars with Ø 3-10 mm**

**Specimen slide for round bars with Ø 10-15 mm**



## IMPRINT



### **Institut Dr. Foerster GmbH & Co. KG**

In Laisen 70  
72766 Reutlingen  
Germany

t +49 7121 140-0  
f +49 7121 140-488  
info@foerstergroup.com

KOERZIMAT 1.097 MS  
MS Measuring systems  
Order number.: 201 678 8  
Edition: 03/2021

Subject to change.

® Registered Trademark in several countries worldwide

© Copyright FOERSTER 2021

**[fluxgate-magnetometer.com](http://fluxgate-magnetometer.com)**  
**[foerstergroup.com](http://foerstergroup.com)**